

# ExpressCam High Performance ExView Cameras KTC-247CE V3/V9

## High-resolution, ExView, Compact Color Camera with Integrated Varifocal DC Auto Iris Lens



The KTC-247C V3/V9 is designed for easy installation.

The KTC-247C is a high-resolution, ExView\*, compact, color camera with integral varifocal DC auto iris lens. The ExpressCam camera series is designed for easy installation and includes a mounting bracket, power supply, and BNC connectors.

\*ExView is a trademark of Sony Corporation.

The KTC-247C offers 480 lines of resolution, high sensitivity (0.1 lux), and advanced digital signal processing. The KTC-247C features digital signal processing. Its automatic backlight compensation prevents important foreground objects from becoming

## Features

- ExView
- 480 lines of resolution
- 0.1 lux sensitivity @ f1.2
- Digital automatic backlight compensation
- Advanced digital signal processing
- Digital horizontal and vertical aperture correction
- Advanced digital auto-tracking white balance
- Integrated DC auto iris varifocal lens: 3–8 mm or 9–22 mm
- 24 VAC
- AC line-lock
- 3x digital zoom
- Mirror function

silhouetted against bright backgrounds.

The KTC-247C has advanced digital auto-tracking white balance (ATW) that provides accurate color rendition even under the most adverse lighting conditions.



## All-in-One Package

KTC-247C Includes camera with built-in varifocal lens, power supply, camera mounting bracket, and BNC connectors.



GE Interlogix

Product  
Specification

© 2003 Kalatel, a GE Interlogix company

# ExpressCam High Performance ExView Cameras KTC-247CE 3V/9V

## Technical Specifications

### Image Device

1/3 in. interline transfer  
Ex-View HAD CCD

### Signal System

NTSC standard, PAL optional

### Picture Elements

811 H x 508 V (NTSC)  
795 H x 596 V (PAL)

### Scanning System

525/60 lines (NTSC), 625/50 lines (PAL)

### Synchronizing System

AC Line lock

### Resolution

480 TV lines

### Sensitivity

0.01 lux (faceplate)  
0.1 lux @ f1.2

### Signal-to-Noise Ratio

>50 dB

### Electronic Shutter

1/60 – 1/100,000 second, automatic

### Color Balance

ATW: Standard range of 2500 to 9500 K  
Fixed: Conventional white balance

### Auto Backlight Compensation

Off/On

### Video Output

Composite: 1.0 V pk-pk at 75 Ω load

### Auto Iris Lens

Integral 3–8 mm or 9–22 mm. DC auto iris

### Operating Temperature

-4 to 122 °F (-20 to 50 °C)

### Power Source

24 VAC

### Power Consumption

2 W

### Weight

7.8 oz (221.125 g)

### Additional Features

3X Digital Zoom

Mirror function

## Dimensions

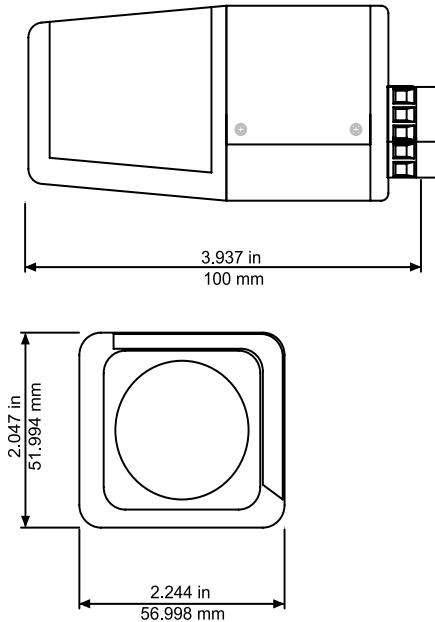

## Connections

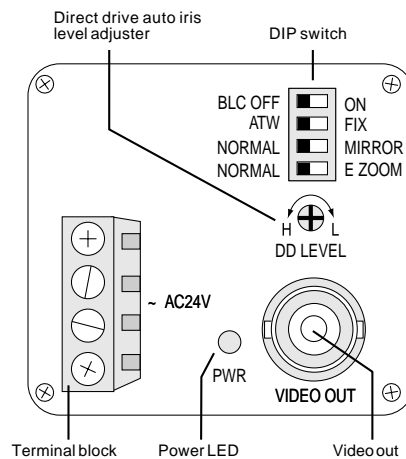

**GE Interlogix**

### MAILING ADDRESS

Kalatel  
4575 Research Way, STE 250  
Corvallis, OR 97333 USA  
www.GE-Interlogix.com

### AMERICAS

800-469-1676 (US only)  
tel 541-754-9133  
fax 541-754-7162

### ASIA

tel 852-2907-8108  
fax 852-2142-5063

### AUSTRALIA

tel 61-3-9259-4700  
fax 61-3-9259-4799

### EUROPE

tel 32-2-725-11-20  
fax 32-2-721-86-13

### LATIN AMERICA

tel 561-912-5321  
fax 561-994-6224